

THIS DRAWING IS UNPUBLISHED. RELEASED FOR PUBLICATION  
 © COPYRIGHT - By - ALL RIGHTS RESERVED.

LOC	DIST	REVISIONS					
AF	50	P	LTR	DESCRIPTION	DATE	DWN	APVD
		E2		REV PER ECO 11-021505	26OCT11	JR	PD

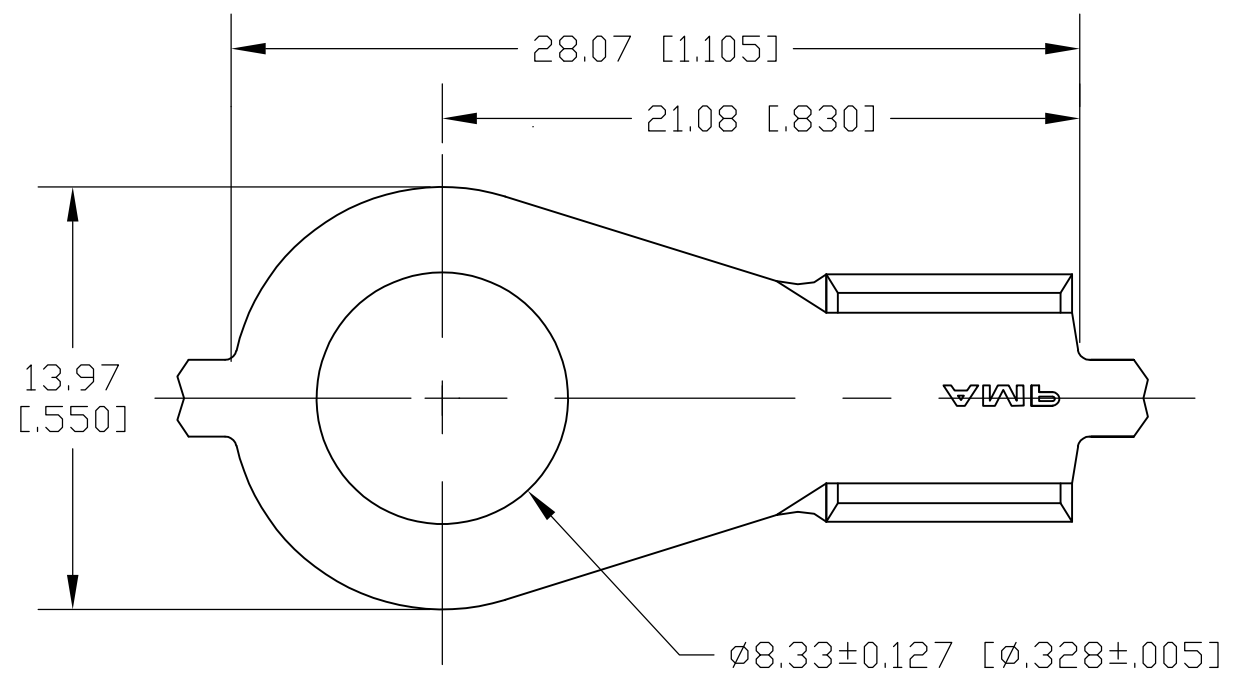

- 1 CONTINUOUS STRIP ON REELS.
- 2 0.00381 [.000150] MIN TIN OVER 0.00254 [.000100] MIN COPPER.
- 3 0.00381 [.000150] MIN TIN
- 4 WIRE SIZE #10-#6 AWG
- 5 PRELIMINARY - NOT FOR PRODUCTION

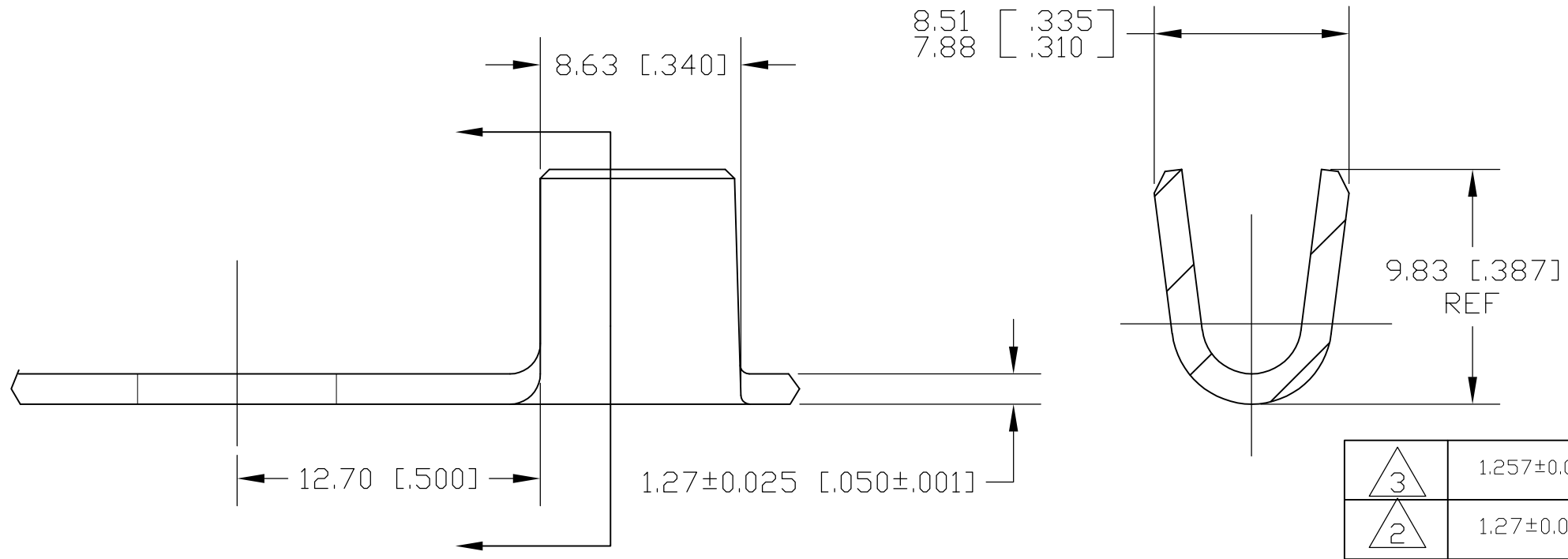

3	1.257±0.025 [.0495±.001] H00 COPPER	5	61546-2
2	1.27±0.025 [.050±.001] 082 BRASS		61546-1
FINISH	MATERIAL	PART NUMBER	

THIS DRAWING IS A CONTROLLED DOCUMENT.		DWN	JR RUTH	28JUN00	<b>STE</b> TE Connectivity			
DIMENSIONS: mm [ INCHES ]		CHK	MS FEHER	28JUN00				
TOLERANCES UNLESS OTHERWISE SPECIFIED:		APVD	G PORTA	28JUN00	NAME			
0 PLC ± - 1 PLC ± - 2 PLC ± 0.38 [.015] 3 PLC ± - 4 PLC ± - ANGLES ± 1		PRODUCT SPEC		RING TONGUE				
MATERIAL SEE TABLE		APPLICATION SPEC		SIZE		CAGE CODE	DRAWING NO	RESTRICTED TO
FINISH SEE TABLE		WEIGHT		A3		00779	C-61546	-
CUSTOMER DRAWING				SCALE	3:1	SHEET	1 OF 1	REV E2